

Cappel CR2

Standard geometries

FRAME SIZE VR		Typical Rider Height	Effective Top Tube Lenght	Seat Tube Lenght to Top	Effective Chainstay lenght	Bottom Bracket Height	Head Tube Lenght	Maximum high	Fork rake	Head Tube Angle	Seat Tube Angle
cm	inch	V-cm	A1-mm	B2-mm	C1-mm	D-mm	F-mm	I-mm	K-mm	α - °	β - °
50	19,7	161-162	529	500	399	268	105	506	43	72	74,2
51	20,1	163-165	534	500	399	268	105	507	43	72,5	74,2
52	20,5	166-167	539	500	399	268	105	507	43	72,5	73,7
53	20,9	168-169	545	510	399	268	115	518	43	73	73,7
54	21,3	171-172	550	520	400	268	125	528	43	73	73,5
55	21,7	173-175	555	530	400	270	135	535	43	73	73,5
56	22,0	176-177	561	540	400	270	145	545	43	73	73,5
57	22,4	178-180	566	550	400	270	155	555	43	73	73,5
58	22,8	181-182	571	560	400	270	165	564	43	73	73,5
59	23,2	183-185	577	570	400	270	175	575	43	73,5	73,5
60	23,6	186-187	583	580	402	270	185	585	43	73,5	73
61	24,0	188-190	589	590	402	270	195	595	43	73,5	73
62	24,4	191-192	595	600	402	270	205	604	43	73,5	73
63	24,8	193-195	601	610	402	270	215	614	43	73,5	73

Geometre je platná pro rok 2009. Výrobce si vyhrazuje právo změny.

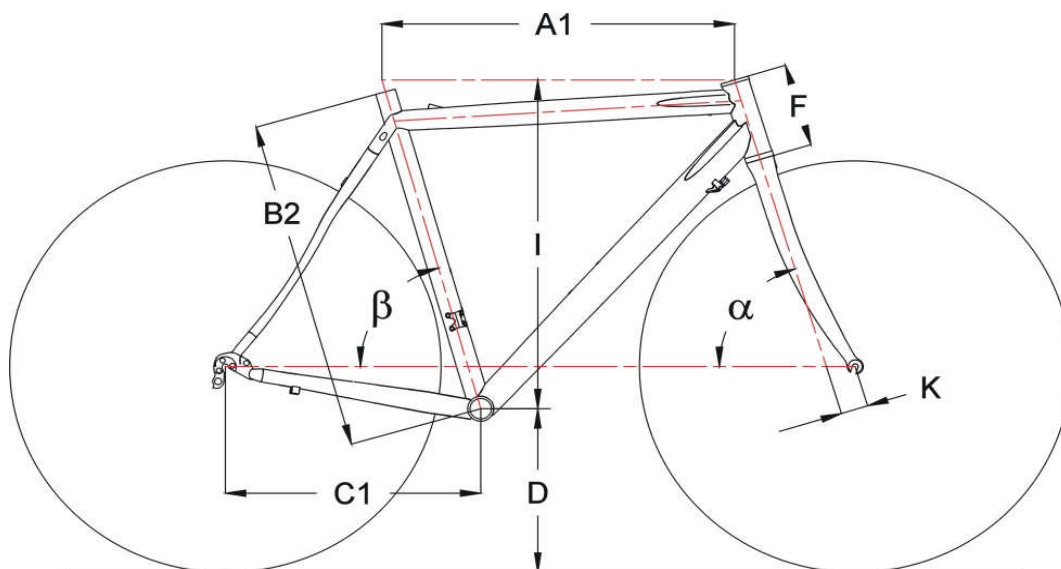

Customer's geometry

FRAME SIZE VR		Typical Rider Height	Effective Top Tube Lenght	Seat Tube Lenght to Top	Effective Chainstay lenght	Bottom Bracket Height	Head Tube Lenght	Maximum high	Fork rake	Head Tube Angle	Seat Tube Angle
cm	inch	V-cm	A1-mm	B2-mm	C1-mm	D-mm	F-mm	I-mm	K-mm	α - °	β - °