

Cult CR3

Standard geometries

FRAME SIZE VR		Typical Rider Height	Effective Top Tube Length	Seat Tube Length to Top	Effective Chainstay length	Bottom Bracket Height	Head Tube Length	Fork rake	Head Tube Angle	Seat Tube Angle
cm	inch	V-cm	A1-mm	B2-mm	C1-mm	D-mm	F-mm	K-mm	a - °	b - °
50	19,7	161-162	529	480	400	268	105	43	72	74,2
51	20,1	163-165	534	490	400	268	105	43	72,5	74,2
52	20,5	166-167	539	500	400	268	105	43	72,5	73,7
53	20,9	168-169	545	510	400	268	115	43	73	73,7
54	21,3	171-172	550	520	400	268	125	43	73	73,5
55	21,7	173-175	555	530	400	270	135	43	73	73,5
56	22,0	176-177	561	540	400	270	145	43	73	73,5
57	22,4	178-180	566	550	400	270	155	43	73	73,5
58	22,8	181-182	571	560	400	270	165	43	73	73,5
59	23,2	183-185	577	570	400	270	175	43	73,5	73,5
60	23,6	186-187	583	580	404	270	185	43	73,5	73
61	24,0	188-190	589	590	404	270	195	43	73,5	73
62	24,4	191-192	595	600	404	270	205	43	73,5	73
63	24,8	193-195	601	610	404	270	215	43	73,5	73
64	25,2	196-198	607	620	404	270	225	43	73,5	73

Geometre je platná pro rok 2009. Výrobce si vyhrazuje právo změny.

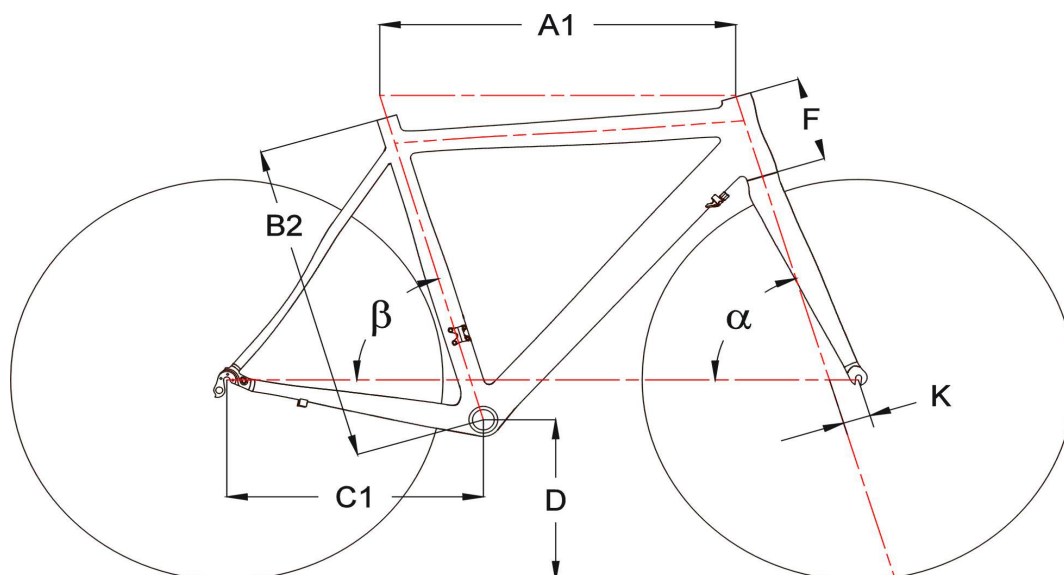

Customer's geometry

FRAME SIZE VR		Typical Rider Height	Effective Top Tube Length	Seat Tube Length to Top	Effective Chainstay length	Bottom Bracket Height	Head Tube Length	Fork rake	Head Tube Angle	Seat Tube Angle
cm	inch	V-cm	A1-mm	B2-mm	C1-mm	D-mm	F-mm	K-mm	a - °	b - °